

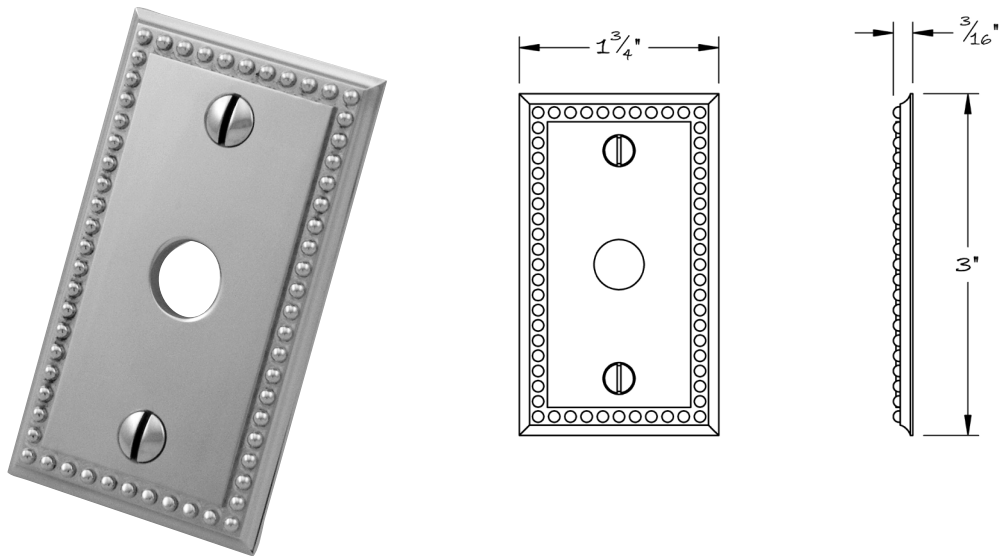

LOWE HARDWARE

No. 1510

LIGHT SWITCH PLATE



*The #1510 light switch plate is bound by a shallow cove and generously spaced beads.*

*This edge detailing is available for escutcheon plates and roses, where they can be machined for use with American or European locks, latches, screen door hardware, or simply as push plates.*

*Also available as a double switch plate.*

*Any of our yacht quality finishes are available. Projection is 3/16"*

• DESIGNED, MANUFACTURED & HAND FINISHED IN MAINE SINCE 1977 •

73 SPRING STREET NEW YORK, NY 10012 (212) 390-0660

WWW.LOWE-HARDWARE.COM